

# S-MLD250 SMT Mini PCB Loader

- Dimension(L\*W\*H) **600**\*650\*1400mm.
- PCBSize: 50\*50-445\*350mm (L\*W)
- Conveyor Height: 900±20mm
- PCB Direction: L to R
- Conveyor speed: 6 seconds
- Power Supply: 220V,50Hz/1Ph 100VAmax
- Capacity: 50 pcs
- Communication:SMEMA Signal
- NetWeight: 100KG

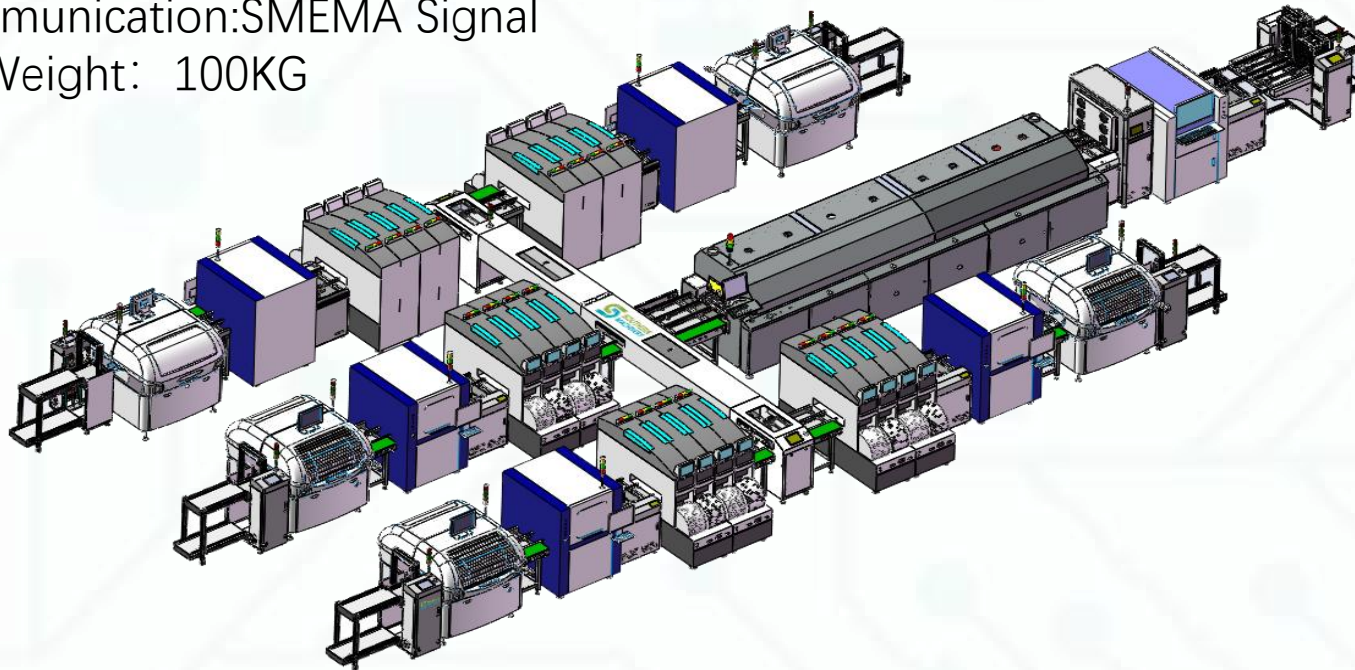

## Product features:

- Suitable for PCB single-sided and double-sided feeding
- PLC + full-color touch screen control
- Motor-driven push board
- Compatible with SMEMA interface

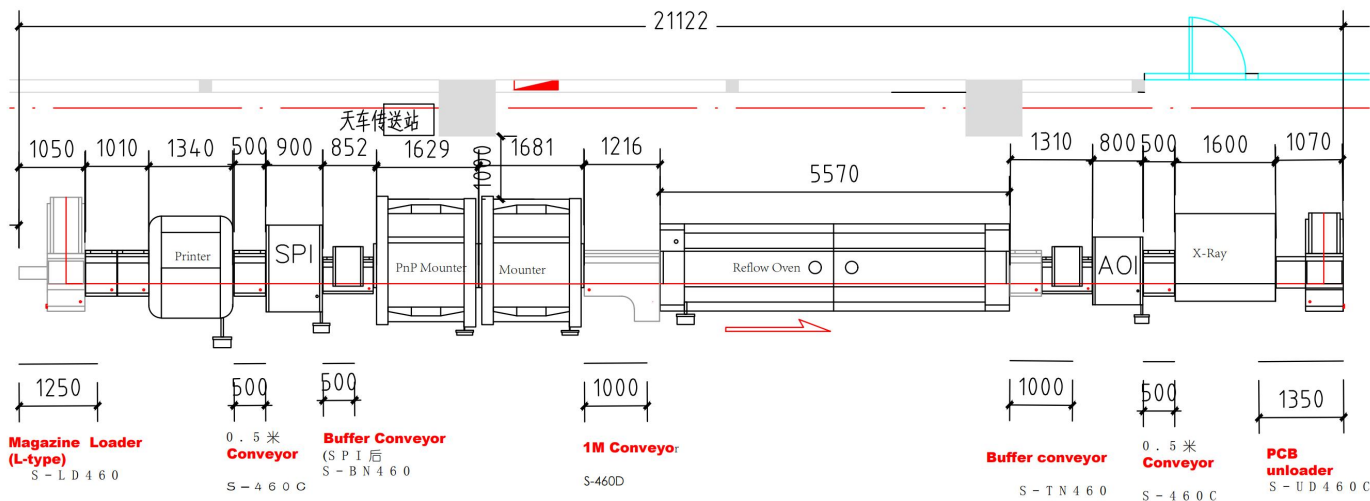

## Product advantages:

- - Sturdy and stable design
- - Simple operation, with multiple sound and light alarm functions
- - Equipped with photoelectric sensing protection, more safe
- - Motor rotates fast and smoothly, accurate positioning

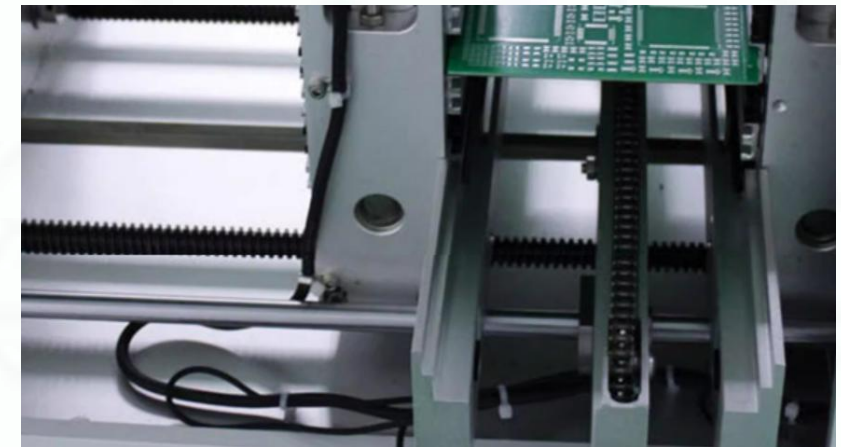
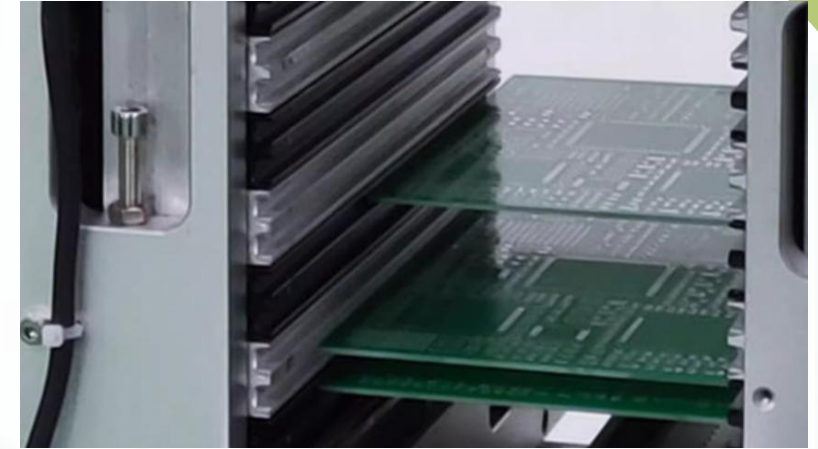
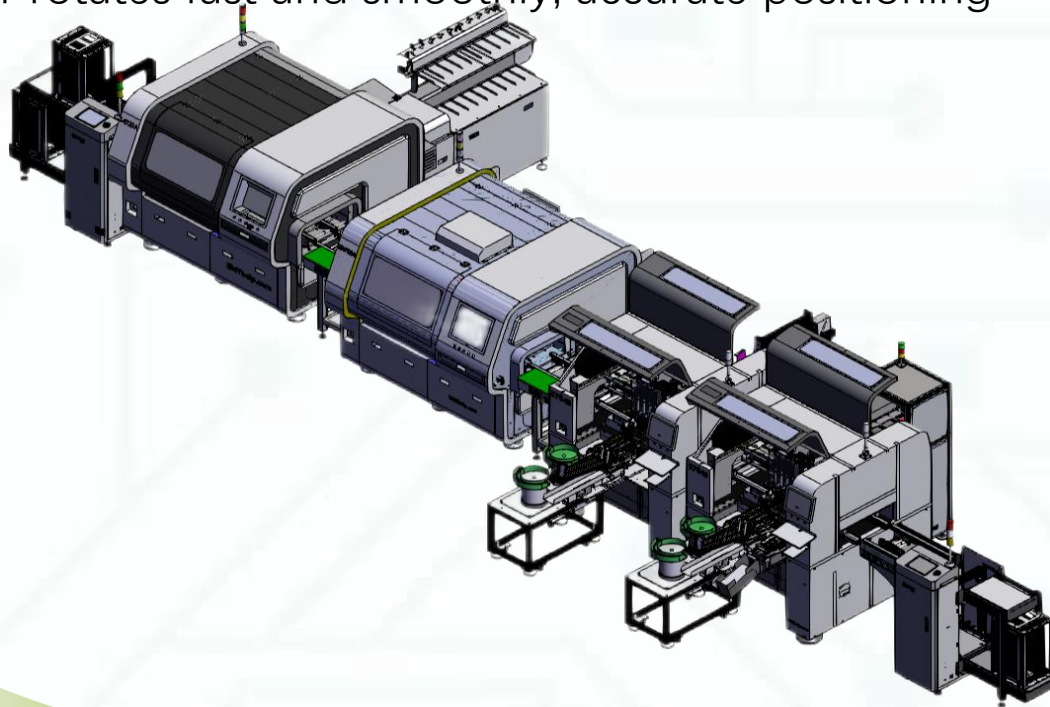



## Product benefits:

- Improve the efficiency and quality of SMT production line
- Save space, reduce labor costs
- Adapt to different specifications of PCB boards, easy to switch



# S-MLD250 SMT Mini PCB Loader



- **7x24 Worldwide Support**
- **Free Installation/ Training**
- **1 day lead-time (spare parts)**
- **1 Month customize solution**



# Welcome Inquiry

Please visit

[www.smthelp.com](http://www.smthelp.com)

Find us more

<https://www.facebook.com/autoinsertion>

Know more our team

<https://www.linkedin.com/company/smtmachine>

Welcome to our factory in Shenzhen China

See more machine working video, please Youtube

<https://www.youtube.com/c/Smthelping>

Google

Auto+insertion, to get more information

Looking forward to your email

[info@smthelp.com](mailto:info@smthelp.com)